



Mobile RAN Telemetry

Three Solutions Scenarios

Mobile Telemetry Challenges

As mobile operators roll out 3G and other wireless broadband services, remote management of cell sites and equipment becomes more important than ever. Yet the complexity of operating, maintaining, and securing wide-area data control networks (DCNs) to handle remote management only continues to increase. Network administrators must monitor and control hundreds – or thousands – of network elements throughout the mobile radio access network (RAN).

Remote elements often span multiple generations of equipment and overlay infrastructure. If each device requires a separate management platform and legacy communication protocol, this drives up infrastructure costs. In addition, when rolling out next generation services, even small outages can mean significant lost revenue, making proactive cell site management even more critical.

Mobile operators need flexible tools for remote monitoring and control. Effective telemetry solutions:

- Allow plug-and-play operation to quickly accommodate future services
- Enable fast, efficient access to remote network elements
- Support remote IP connectivity to each site and each device
- Permit protocol/topology segmentation for security reasons
- Integrate easily with third-party performance management platforms

The DNX-1u Access Gateway and DNX-11/88 Cross-Connects from Sycamore Networks answer the telemetry challenge. Both platforms combine intelligence and sophisticated telemetry capabilities with multiple transmission interfaces and cross-connect functionality, for use at cell sites and core switching centers.

The following case studies illustrate the significant financial and operational benefits of applying the DNX solution to remote cell site and data control network management challenges.

Case Study #1: Large GSM Operator in South Africa

Background

South Africa is home to three GSM operators and one of the fastest growing mobile markets in the world. With penetration of only 40%, all three companies are experiencing massive subscriber growth. Competition is fierce and 3G services are becoming established in the country.

To stand out from the others, one of the operators would like to offer more reliable services at lower operational expense, freeing them to focus on new service offerings. Cell site theft and vandalism are major issues, magnified by having little or no visibility and control of remote sites. Rectifiers, battery controllers, and similar devices can only be managed locally. If an outage occurs, staff technicians often arrive on site only to realize they do not have the correct tool or spare part to fix the problem. In addition, leased E1 backhaul circuits are of poor quality, and there is no effective way to monitor performance and enforce SLAs.

Deploying the carrier-class DNX-1u Access Gateway at approximately 500 cell sites in the northeast part of the country combats these problems. Acting as a telemetry hub, the DNX-1u enables IP-based remote management and control of all 3rd-party equipment at the cell site over a single 64 kbps channel in a backhaul E1.

Elements controlled or monitored by the DNX-1u include:

- Site access controller and IP camera
- Battery/Rectifier system, including voltage measurement
- Radio (B-Mon VSWR Calibration)
- Diesel fuel levels in generators
- Environmental (temperature and humidity sensors)
- Tower aircraft warning light

Operations staff can connect to the corporate network from cell sites to access technical manuals, review work orders, and check e-mail, greatly enhancing their productivity while in the field. The Network Operations Center (NOC) can monitor and troubleshoot problems on the backhaul E1 links (e.g., perform loopbacks and bit error-rate tests) in support of SLA enforcement.

Using the Sycamore Networks solution to centrally manage a large number of cell sites improves network reliability and significantly reduces OpEx. The payback period in OpEx savings alone is just over 12 months, and improves even further if revenues not lost due to outages and customer churn are taken into consideration.

THE PROBLEM

Minimal visibility into cell sites contributes to long outage times, site break-ins, and overstretched operations teams. Performance monitoring on leased E1 backhaul circuits is impossible, making enforcement of service level agreements (SLAs) extremely difficult.

THE SOLUTION

Leverage the DNX-1u Access Gateway as a telemetry hub for remote cell site management. Savings from theft reduction alone could reach US \$500,000 annually, with average outage times reduced from 17 to 7 hours.



DNX-1u as a Mobile Cell Site Telemetry Hub

SUMMARY

Before	After
\$500,000 in theft-related capital losses	\$1,300,000 savings from reduced theft, fewer truck rolls and contractor fees, and shorter outage times
\$1,000,000 in overtime/travel expenses for on-site troubleshooting and contractor fees	90% reduction in travel/labor expenses and theft occurrences
17 hour average outage time due to battery/rectifier failures	Power outage average time reduced to 7 hours, with savings of \$140,000
4,200 incidents on backhaul E1s with no reimbursements for SLA violations	\$300,000 in reimbursements from incumbent carrier for SLA violations
\$46,000 in fines due to faulty aircraft warning lights	Aircraft warning light faults resolved quickly, resulting in no fines paid

Case Study #2: Large GSM Operator in Turkey

Background

This mobile operator uses equipment from three microwave vendors for backhaul, and hundreds of links are unmanaged. Microwave faults are common, and lack of remote visibility means hours or even days can pass before the operator becomes aware of them. Troubleshooting can only be done locally, requiring technicians to travel long distances to one or more remote sites in order to resolve problems. If the technician does not have the right tool or spare part to fix the problem, he then has to travel to the nearest spares depot and back again before beginning repair work. In such a vast and mountainous country, unnecessary truck rolls cause considerable strain for operations teams.

DNX-1u in a Multi-Vendor Microwave Management Role

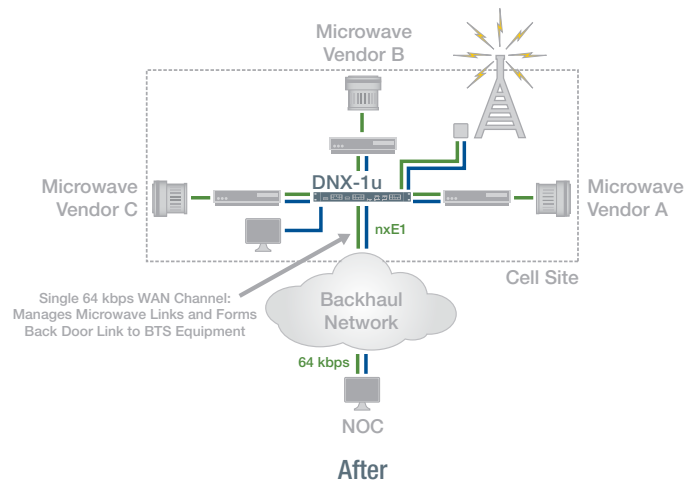
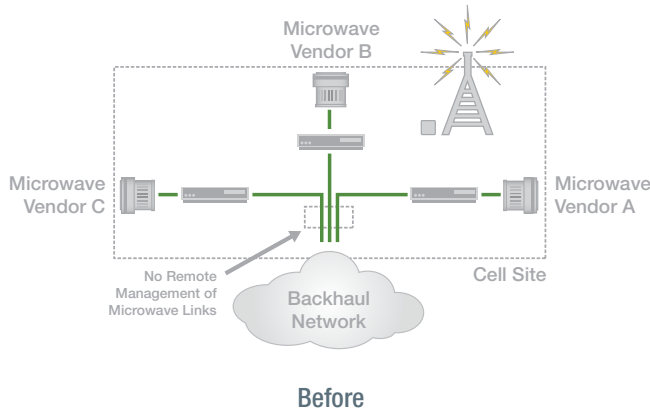

Deploying the DNX-1u Access Gateway as a remote management hub in 200 cell sites enables the operator to centrally manage hundreds of microwave links, from multiple vendors, over dedicated IP management channels provisioned in the backhaul E1s.

The operator can isolate and resolve microwave faults faster, substantially reduce outage times, and use operations resources more efficiently. The integrated terminal server in the DNX-1u provides an RS-232 “back door” management link to BTS equipment. If the in-band channel goes down, this link can control the BTS during remote software downloads and other maintenance tasks, considerably reducing the need for site visits.

THE PROBLEM

An unmanaged, multi-vendor microwave backhaul network makes outages difficult to isolate and troubleshoot. The operator needs an out-of-band solution to remotely manage base transceiver station (BTS) equipment.

THE SOLUTION

Deploy the DNX-1u Access Gateway as a remote IP hub to manage microwave links and provide an alternative management channel to BTS systems. Annual savings from reduced truck rolls and previously lost revenue could approach US \$800,000.

SUMMARY

Before	After
Hundreds of truck rolls to identify and troubleshoot microwave faults	\$275,000 savings from reduced truck rolls
Microwave outages sometimes last for days before being noticed	Outage times reduced from days to hours, saving over \$500,000 in lost revenue
BTS software downloads require on-site support	Remote BTS management via backup link improves software upgrade times by 80%
Operations teams severely over-stretched	Remote IP management of hundreds of microwave links frees operations resources

Case Study #3: Large Fixed/Mobile Operator in Mexico

Background

This operator employs a vast DCN to centrally manage remote BTS systems and third-party equipment at cell sites. All management traffic is backhauled to a core switching site for aggregation by a digital cross-connect system (DCS) onto DS3 and STM-1 circuits for handoff to the core IP network; from there it is routed to the NOC.

This architecture requires an enormous amount of bandwidth and port resources on both DCS and router platforms for non-revenue generating management traffic. DS3 and STM-1 port cards on the router are expensive and consume backplane and routing capacity inefficiently. Both platforms are at their capacity limits and expansion would require additional capital expenditure (CapEx).

DNX-11/88 with Circuit/Package eXchange (CPX) for IP/DCN Management Traffic Optimization

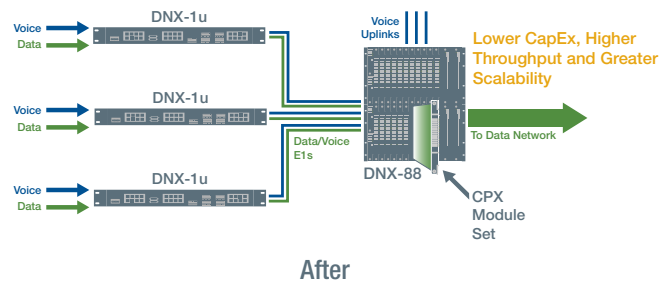
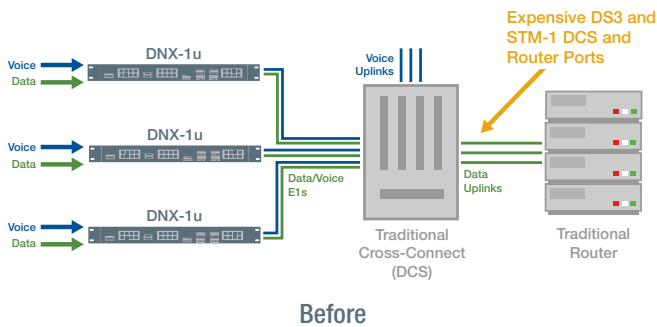

Deploying the DNX-88 Cross-Connect system with the channelized CPX module set optimizes router utilization. The CPX has a capacity of 16 T1/E1 virtual WAN interfaces, and is fully interoperable with Ethernet/PPP-compliant routers. Integrated IP routing functionality directly interconnects with the DNX cross-connect fabric, distinguishing the CPX solution from standalone DCS and separate router alternatives.

The DNX-88/CPX solution efficiently aggregates thousands of DCN circuits and encapsulates them into 10/100 Ethernet for hand-off to the IP network, considerably reducing router and DCS port costs. In addition, integrated diagnostics provide advanced troubleshooting capability on DCN links, improving DCN reliability. Because the DNX-88 is a small footprint switch that can scale up to 500 E1s, the operator has ample capacity for network expansion.

THE PROBLEM

DCN communication channels from remote sites consume too much bandwidth and port capacity on core IP routers.

THE SOLUTION

Utilize the Ethernet capabilities of the DNX-88 Cross-Connect with Circuit/Package eXchange (CPX) module set to efficiently aggregate DCN channels from the access network and hand off management traffic to the IP network. Subsequent CapEx savings, and capacity optimization on expensive router ports, make this solution financially attractive.

SUMMARY

Before	After
Core IP routers require expensive DS3 and STM-1 ports to support DCN traffic	Consolidating DCN traffic onto Ethernet saves \$30,000 in DS3/STM-1 port cards and defers CapEx for both DCS and router platforms
DCS and router platforms approaching maximum capacity, mainly due to increasing DCN traffic volume	Enhanced diagnostics improve DCN reliability and reduce OpEx
Limited visibility on DCN circuits impairs reliability	Interface flexibility and exceptional port density on the DNX-88 ensure scalability as the network grows

Sycamore Networks Telemetry Solution Highlights

Individually, the DNX-1u and the DNX-11/88 offer significant telemetry and DCN advantages, and they can be used together for end-to-end telemetry and management optimization in a mobile network. The unique telemetry, IP routing, and cross-connect features in a DNX solution deliver functionality that goes beyond traditional backhaul bandwidth optimization, to help operators resolve the operational challenges associated with managing highly-distributed mobile networks.

DNX-1u Access Gateway

The DNX-1u combines sophisticated telemetry capabilities with multiple transmission interfaces and digital cross-connect functionality. This intelligent platform eliminates the need for separate CSU/DSUs, hubs, switches, routers, remote test equipment and associated cabling at cell sites and other remote locations with diverse system management needs.

Eight ports of 10/100 Ethernet combine with Layer 2 switching and channelized routing, for IP connectivity to the site. Two synchronous EIA-530/ITU X.21/V.35 interfaces provide access for Nx56/64 serial data, while six asynchronous EIA-232/ITU V.24 interfaces deliver the terminal server functionality needed to manage legacy equipment.

The DNX-1u Access Gateway monitors signal levels and activates or resets remote devices via input/output contact closures. The DNX-1u can use SNMP to send alarm notifications, which simplifies integration with other network performance monitoring and management tools.

EXAMPLE MANAGED SITE ELEMENTS

- Radio Access Network Equipment – BTS, Node B, BSC, RNC
- Microwave Systems
- Power Management Systems – Power distribution, battery back-up and rectifiers, generators
- Heating, Ventilation, and Air Conditioning (HVAC) Systems
- Access Control Systems – Card readers (entry and exit), door locking mechanisms, and logging software
- Surveillance Systems – Closed-circuit video and Ethernet-based webcams
- Remote Electrical Downtilt

DNX-11/88 with Circuit/Packet eXchange (CPX) Module Set

The DNX-11/88 Cross-Connect platform supports a range of interface types, including T1/E1, DS3/E3, OC-3/STM-1 and numerous data and voice interfaces. The system scales to over 600 T1s or 500 E1s, ensuring cost-effective, space-efficient growth and excellent investment protection.

Unique in the industry, the CPX module set aggregates DCN traffic coming into the core mobile switching center (MSC) site from the RAN onto 10/100 Ethernet for efficient handoff to the operations center. This approach reduces port costs within the MSC and preserves routing capacity on large router platforms located deeper in the network. The CPX is compatible with Ethernet/PPP-compliant routers, and supports packet traffic from up to 384 DS0s or 16 T1/E1 virtual WAN connections.

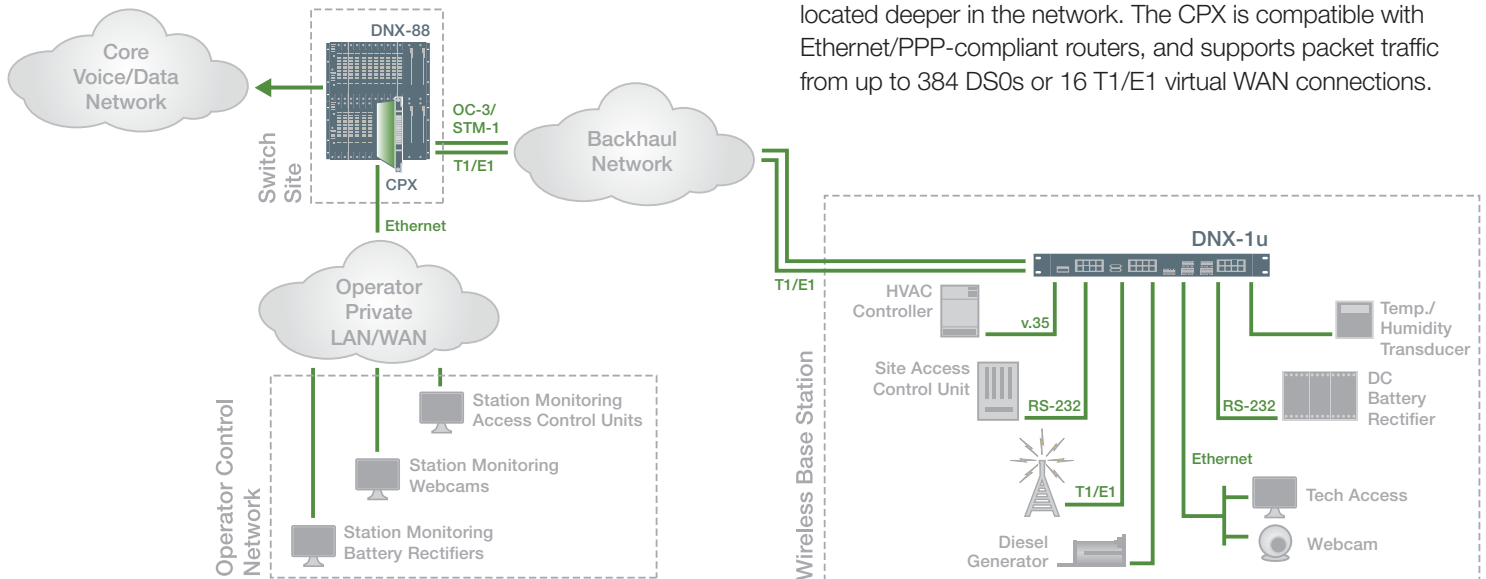

Integrated Mobile RAN Management with DNX-1u and DNX-11/88

Advantages of an Integrated Approach

These case studies exemplify the remote management and telemetry benefits of DNX solutions from Sycamore Networks. The highly distributed nature of cell site infrastructure, geographic remoteness of many sites, and heterogeneous mix of equipment (both network and non-network elements) can negatively impact mobile network operations. Feature-rich DNX products overcome these limitations.

Sycamore telemetry solutions enable network operators to isolate and analyze alarms prior to dispatching technicians. This reduces or eliminates unnecessary site visits, making it possible to resolve problems in minutes, rather than hours. Minimizing truck rolls, travel time, and related service costs can substantially reduce operating expenses. DNX solutions can also conserve expensive port and routing capacity, and curtail revenue losses due to service outages or dissatisfied customers. For network operators, all of these advantages add up to faster service restoration, lower CapEx and OpEx, and reduced churn.

The DNX-1u Access Gateway and DNX-11/88 Cross-Connects offer economical applications flexibility, and are deployed today in major operator networks worldwide. Integrated telemetry solutions from Sycamore Networks offer mobile operators a fast, simple way to improve operational efficiency, reduce costs, and enhance profitability.

For more information about our intelligent networking products and solutions, please contact your Sycamore Sales Representative.

Sycamore Networks, Inc. • 220 Mill Road • Chelmsford, MA 01824-4144, USA • Phone: 978-250-2900 • Fax: 978-256-3434 • www.sycamorenet.com

Sycamore Networks, Inc. (NASDAQ: SCMR) is a leading provider of intelligent bandwidth management solutions for fixed line and mobile network operators worldwide. From multiservice access networks to the optical core, Sycamore products enable network operators to lower overall network costs, increase operational efficiencies, and rapidly deploy new revenue-generating services.

Sycamore assumes no responsibility for the accuracy of the information presented, which is subject to change without notice. Sycamore and Sycamore Networks are trademarks or registered trademarks of Sycamore Networks, Inc. in the United States and/or other countries. Copyright © 2009 Sycamore Networks, Inc. All Rights Reserved.

